

Preservation  
sub-zero



MDF-C2156VAN



### Temperature

(Ambient temperature 30°C)

**-150°C**

### Effective capacity

**231 liters/8.2cu.ft.**

### **V.I.P. PLUS**

(Vacuum Insulation Panel)

### Ideally suited for cryogenic and long-term storage in laboratories

- V.I.P. PLUS technology maximises storage capacity.
- Comfortable operation via LCD control panel
  1. Chamber temperature recorded for up to 1 month
  2. Warning messages displayed in LCD panel
  3. Records history of door opening/closing (more than 2 minutes)
- Safe operation with status alert continuous condition monitoring
- Equipped with LN<sub>2</sub> backup system as standard
- Can hold up to 14,000 tubes (2 ml)

# MDF-C2156VAN

## Features

### Design

- PHCbi V.I.P. PLUS -150°C cryogenic freezers use patented revolutionary vacuum insulation cabinet construction that reduces the wall thickness from 175 mm to 135 mm (6.9" to 5.3") and achieves up to 25 % more storage capacity than a conventionally insulated freezer without increasing the footprint.
- The newly developed refrigeration system and the freezer structure offer a quiet experimental environment.
- Achieves 50 % higher energy conservation than previous model. (For model rated 220 V, 50 Hz)

### Reliability

- Status alert monitors ambient and system conditions continuously and notifies of any abnormalities before a problem happens.
- Equipped with LN<sub>2</sub> backup system as standard to prepare for any contingency.

### Ideal replacement for LN<sub>2</sub> storage

Compared to liquid nitrogen systems, PHCbi MDF-C2156VAN offers the following advantages:

- Lower running cost
- Easy maintenance
- No occurrence of contamination

## Performance Data

### Pull-down characteristics

### Pull-up characteristics during power failure

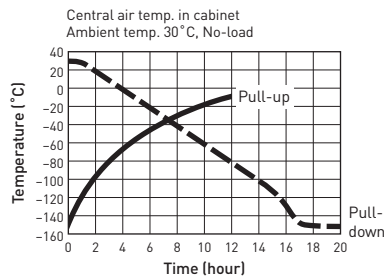

### LN<sub>2</sub> back up system operation characteristics

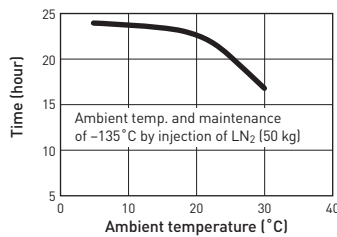

## Innovative Control Panel

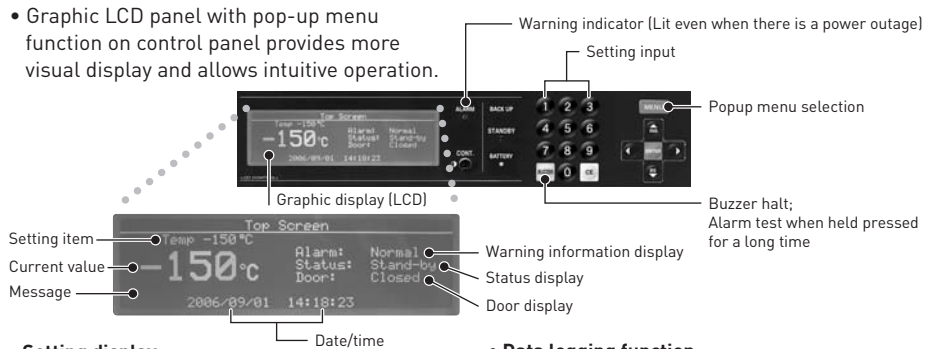

### Setting display

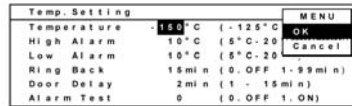

### Access control

To prevent unauthorized access to freezer settings, the key lock can only be cancelled by inputting the password.

### Data logging function

Recording of internal temperature for 1 month or 1 week period Recording of history of door opening/closing (more than 2 minutes)

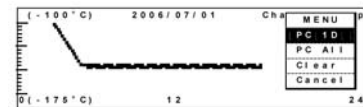

## Specifications

	Model No.
220 V, 50 Hz	MDF-C2156VAN-PB
220 V, 60 Hz	MDF-C2156VAN-PK
230 V/240 V, 50 Hz [CE]	MDF-C2156VAN-PE
Temperature range	-125°C to -150°C (in 1°C increments)
Maximum cooling performance	-150°C (Ambient Temperature 30°C)
External dimensions (W x D x H)*1	1730 x 765 x 1010 (mm) / 68.1 x 30.1 x 39.8 (inch)
Internal dimensions (W x D x H)	760 x 495 x 615 (mm) / 29.9 x 19.5 x 24.2 (inch)
Net weight	Approx. 318 kg (701 lbs.)
Effective capacity	231 liters (8.2 cu.ft.)
Access port	40 mm diameter, 1 location
Compressor	Hermetic type, Output: 1100 W (high stage side), 1100 W (low stage side)
Refrigerant	HFC
Alarms	High/Low temperature, Power failure, Filter check, Self diagnosis, Door check, Part replacement notification
Remote alarm contact	Allowable contact capacity, DC 30 V, 2 A
Accessories	1 set of keys, 1 scraper, Connecting tube for LN <sub>2</sub> backup system

\*Cooling performance is indicated by the temperature reached at the center of the freezer [at ambient temperature of 30°C with no load]. In order to use the freezer at a stable temperature for a long time, it is recommended that the temperature be set to at least 5°C higher than the indicated lowest temperature.

In addition, depending on the usage conditions, it may not be possible to reach the indicated lowest temperature.

**Caution:** PHC Corporation guarantees the product under certain warranty conditions. PHC Corporation is in no way shall be responsible for any loss of content or damage to content. The battery for power failure alarm is an article for consumption. It is recommended that the battery will be replaced about every 3 years.

• Appearance and specifications are subject to change without notice.

\*1 External dimensions of main cabinet only - see dimension drawings showing handles and other external projections.

## Dimensions

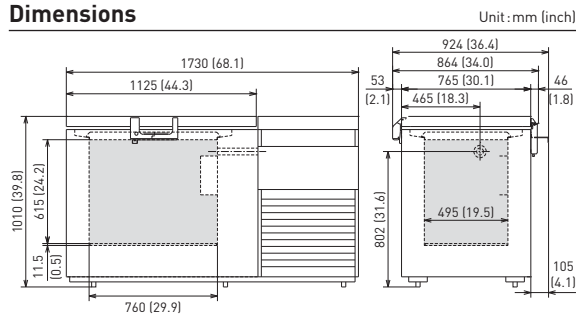

## Options

- Strip chart recorder **MTR-155H-PW**
- Recorder mounting bracket (for MTR-155H-PW) **MDF-S30150-PW**
- Inventory rack **IR-210C-PW**
- Max capacity: 14pcs Ink pen **DF-38FP-PW**
- Chart paper **RP-155**

Interface board  
(For data acquisition system MTR-5000 users only)  
**MTR-L03-PW / MTR-480-PW**



### Preservation (freezers, refrigerators) and Culturing (incubators) Equipment

The management of the design, development, production, sales support, and servicing of the above.

PHC Corporation, Biomedical Division

1-1-1 Sakada, Oizumi-machi, Ora-gun, Gunma 370-0596, Japan



PHC Corporation, Biomedical Division is certified for:

**Environmental management system: ISO14001**

DISTRIBUTED BY:

**phcbi**  
PHC Corporation

<https://www.phchd.com/global/biomedical/>

Printed in Japan 1202-2018-04-BA