



Temperature

Ambient temperature **+5°C to 80°C**

Effective capacity

93 liters/3.3 cu.ft. (MIR-H163)

153 liters/5.4 cu.ft. (MIR-H263)

Microprocessor PID Control + Air Jacket

Heated Incubators provide a precise and stable incubation environment

- A wide range of applications including biological cultures and environmental studies
- Accurate temperature control by Microprocessor PID control system and Air Jacket system
- Operation timer function
- Alarms and self diagnostic function secure safe operation.



MIR-H163

MIR-H263

MIR-H163/MIR-H263

Features

Microprocessor PID control + Air Jacket system

Microprocessor PID control and Air jacket system give precise temperature control within the chamber. Temperature accuracy is within $\pm 0.2^{\circ}\text{C}$ (at setting temperature 37°C) and temperature uniformity is within $\pm 1.0^{\circ}\text{C}$ (at setting temperature 37°C).

Microprocessor timer function

An accurate microprocessor timer is fitted to allow esired start time is set by an automatic start (delay function). An information function activates a buzzer when a set time is over and keeps a set temperature after an operation finishes. Various operation patterns can be set by utilizing these functions.

Timer set patterns

Automatic stop function

Heater will be off after a set operation is over.

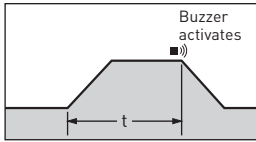

Information function

Continues operating after a set operation is over.

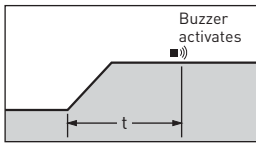

Temperature control range — Ambient temperature $+5^{\circ}\text{C}$ to 80°C (AT 20°C)

PHCbi heated incubators allow incubation at normal temperature to high temperature.

User-friendly design

Control panel uses a touch keyboard and an easy-to-read green LED display. Temperature and time are shown respectively by digital displays. Durable stainless steel for interior cabinet.

Control panel



Specifications

	Model No.	
115 V, 60 Hz	MIR-H163-PA	MIR-H263-PA
220 V, 50/60 Hz	MIR-H163-PK	MIR-H263-PK/MIR-H263-PR
230 V/240 V, 50 Hz (CE)	MIR-H163-PE	MIR-H263-PE
External dimensions (W x D x H)*1	580 x 595 x 820 (mm)	730 x 645 x 870 (mm)
	22.8 x 23.4 x 32.3 (inch)	28.7 x 25.4 x 34.3 (inch)
Internal dimensions (W x D x H)	450 x 460 x 450 (mm)	600 x 510 x 500 (mm)
	17.7 x 18.1 x 17.7 (inch)	23.6 x 20.1 x 19.7 (inch)
Effective capacity	93 liters (3.3 cu.ft.)	153 liters (5.4 cu.ft.)
Shelves	Stainless steel, Stainless wire	
	2	3
Circulation system	Natural convection (Air Jacket system)	
Temperature control system	Microprocessor PID system	
Timer	Automatic timer with delay function 00:00 – 99:59	
Heater	Sheathed heater 200 W	Sheathed heater 300 W
Sensor	Thermistor	
Temperature range	Ambient temperature $+5^{\circ}\text{C}$ to 60°C (AT 0°C to 20°C),	
	Ambient temperature $+5^{\circ}\text{C}$ to 80°C (AT 20°C to 35°C)	
Temperature control accuracy	$\pm 0.2^{\circ}\text{C}$ (to $+60^{\circ}\text{C}$) $\pm 0.5^{\circ}\text{C}$ ($+60^{\circ}\text{C}$ to 80°C)	
Temperature uniformity	$\pm 1.0^{\circ}\text{C}$ (AT 20°C , Setting temperature 37°C)	
Net weight	50 kg (110 lbs.)	67 kg (148 lbs.)

Various alarm functions

Various alarm functions and a diagnostic function are equipped to protect specimens.

Alarm system	Condition for action	Actions
Temperature alarm	$\pm 2.5^{\circ}\text{C}$ deviation from set temperature	Lamp, LED, Buzzer
Independent temperature rise prevention system	When temperature rises over limited temperature	Out of operation: Buzzer In operation: Lamp, LED, Buzzer Heater will be turned off by an independent system
Key-lock switch	When key-lock is on	Does not accept key entry (except a buzzer call key)
Memory back-up	When power failure occurs and power plug is off	Memorises the pattern of set temperature & time
Self diagnostic system (problem monitor)	When faults occur	Fail-safes and displays E01 - E05

Caution: PHC Corporation guarantees the product under certain warranty conditions. PHC Corporation is in no way shall be responsible for any loss of content or damage to content.

• Appearance and specifications are subject to change without notice.

*1 External dimensions of main cabinet only - see dimension drawings showing handles and other external projections.

Temperature uniformity data

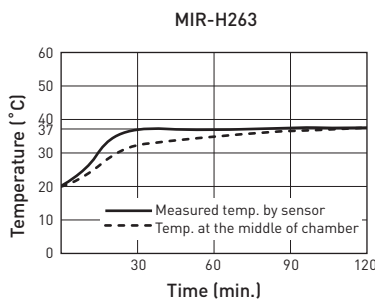
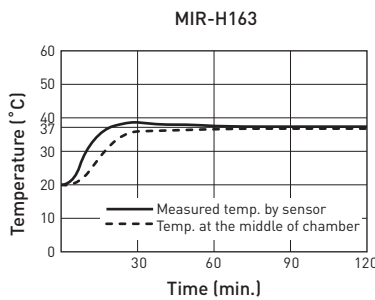

Dimensions

Unit : mm (inch)

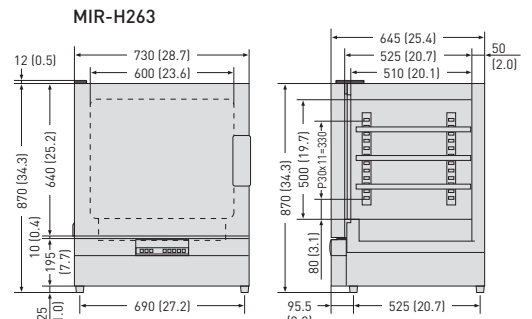
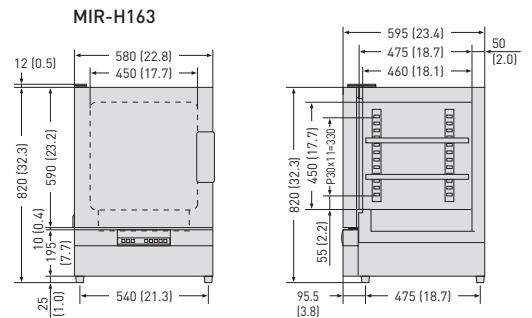

DISTRIBUTED BY:

PHCbi
PHC Corporation

<https://www.phchd.com/global/biomedical/>

Printed in Japan 4105-2018-04-BB